

NEW

96-Series 48V Alternators Mid-Duty Cycle, Large Frame Alternators

- 60A (2.9 kW) or 100A (4.8 kW) at 48 Volts
- Low Turn-On Thresholds
- Low Power Take Off at Idle Speed
- Designed for External Regulation using the Balmar MC-620 Regulator
- Ideal for 48V Lithium Battery Banks



New 96-Series Alternators from Balmar establish a new standard for emerging 48V battery banks and inverter systems.

Paired with the **New MC-620 Regulator**, now you can combine the advantages of Balmar's legendary multi-stage regulation capability in a 48V charging system. Offered in two power packages of 60A and 100A, these high power alternators provide 2.9 kW and 4.8 kW of charging power, respectively.

48V systems fill the need for ever-increasing power needs from DC battery systems. DC air-conditioning and cooking, for example, can stretch 12V and 24V systems beyond practical application. The benefits of a 48V system include much more efficient components, such as chargers and inverters, manageable cable sizes, and of course higher output alternators in reasonable package sizes. Lithium batteries can be charged at very high rates – a 48V system can accomplish this in a cost effective way. With lower 1,325 RPM (60A) and 2,250 RPM (100A) cut-in speeds than the competition, the 96-Series starts making power earlier at low RPM, limiting the need for complex pulley schemes or over-throttling the engine at idle.



MC-620-H



MC-TS-A
MC-TS-B

Contact Balmar Tech Service to learn more about the **New 96-Series Alternators!**

Part Number ⁽¹⁾	Output		Grounding	Power Take Off	Mounting Style	Standard Pulley
	Volts	Amps				
96-48-60-K6	48V	60A	Case	Up to 8 HP	Dual Foot 4" (J-180)	K6 (2.7" Dia.)
96-48-60-K6-IG			Isolated			
96-48-100-K8		100A	Case	Up to 11 HP		K8 (2.5" Dia.)
96-48-100-K8-IG			Isolated			
Part Number	Power Input		Battery Profiles			
MC-620-H	12V		Universal, Deep Cycle Flooded, Gell Cell, AGM, Spiral Wound Flooded, Standard Flooded, Halogen, Lithium			
MC-TS-A	Alternator Temp Sensor					
MC-TS-B	Battery Temp Sensor					

(1) Balmar's 96-Series 48V Alternators are designed to be used with the MC-620 Multi-Stage Regulator.

Caution: The MC-620 Regulator requires up to 12V to power the device, it cannot be powered from a 48V source.

Alternator Output Curves

Alternator output is dependent upon a number of factors: battery condition and capacity, wire size, engine horsepower and RPM, battery temperature and alternator temperature. Of these factors, alternator speed and temperature are most important. The following graph describes alternator output based ambient (30°C) conditions where the alternator dwells at a specific RPM until the temperature stabilizes. Test voltages are set at 54.0V.

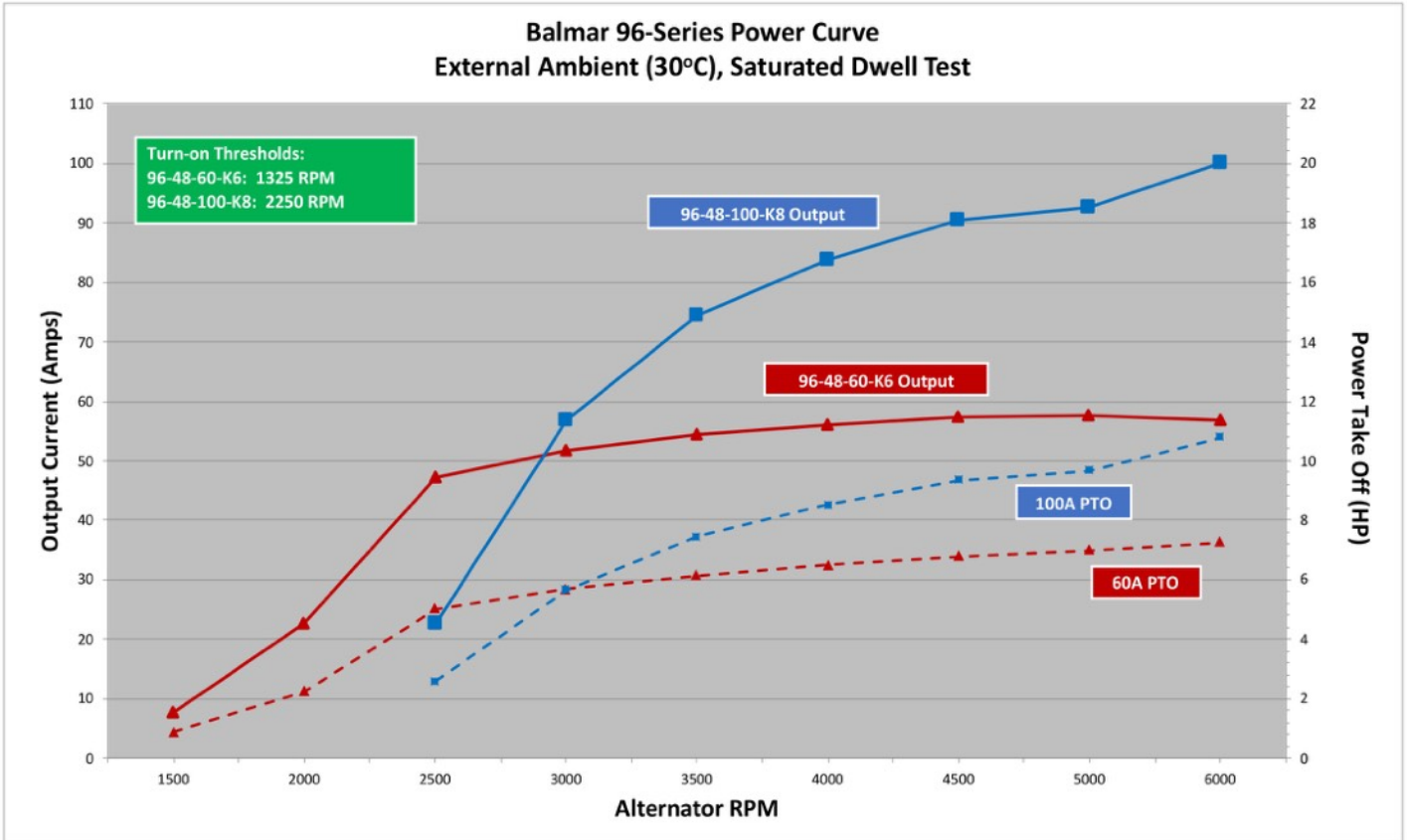

96-Series Alternator Specifications

Alternator Style: Large Case, Positive Field Excitation (P-Type)	AC/Stator Output: 12 Poles Stator Output Wire included in Pigtail Plug
Regulation: External P-Type (MC-620) The Alternator Will Not Operate without the MC-620 External Regulator. 12V Supply to Regulator Required	B+ Positive Output: Threaded Stud, M8 x 1.25" B- Terminal: Threaded Stud, M6 x 1.0" L Terminal: Threaded Stud, M5 x 0.8"
Cooling: Dual Internal Fans	Grounding: Case or Isolated Ground Available
Bearings: Sealed Bearings, Heavy Duty Radial (front & rear)	Mounting Style: 4" Dual Foot Saddle (J-180)
Case Construction: Ventilated Cast Aluminum	Diodes +/-: 6 Positive, 6 Negative; 50A Rated
Finish: Clear Anodize	Weight: 9kg (19.8 pounds)
Tensioning Arm Mount: 13mm (1/2") Mounting Foot Bore: 13mm (1/2")	Normal Operating Temperature: 180°F / 82°C Max Operating Temperature: 225°F / 108°C
Low RPM Cut-In: 60A: 1,325 rpm, 100A: 2,250 rpm	Max Alternator RPM: 12,000 rpm
Ignition Protection Ratings: TBD	

96-Series Dimensions

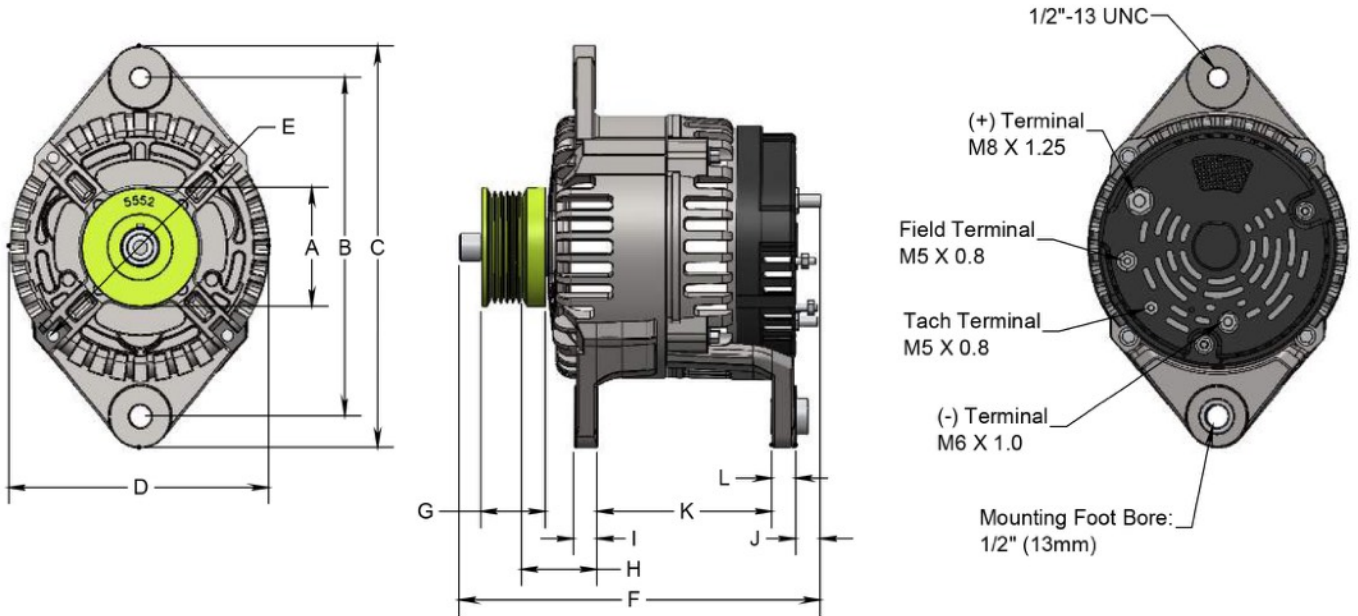

ITEM	DESCRIPTION	IN.	mm
A	K6 (Serpentine) Pulley Dia.	2.74	69
	K8 (Serpentine) Pulley Dia.	2.57	65
B	Mounting Hole to Hole	7.80	198
C	Overall Height	9.22	234
D	Case Diameter	6.11	155
E	Mounting Ear to Mounting Ear	5.90	149
F	Overall Length	8.62	219
G	K6 Pulley Width	1.50	38
	K8 Pulley Width	1.50	38

ITEM	DESCRIPTION	IN.	mm
H	First Groove to Mounting (K6)	1.60	40
	First Groove to Mounting (K8)	1.53	38
I	Foot Thickness	0.55	14
J	Foot to (+) Terminal	0.59	15
K	Saddle Width (MIN)	3.76	95
	Saddle Width (MAX)	4.39	111
	Saddle Width	4.07	103
L	Rear Foot Thickness	0.55	14

Application notes: In a typical installation the 48V alternator is installed as a secondary alternator on the engine, as most engines have a 12-24V starter system. If installed as the only alternator, a starter battery can be charged by an appropriate DC-DC charger.

A complete 48V system could be comprised of:

1. A 96-Series alternator.
2. MC-620 Regulator and Harness.
3. Alternator and Battery (optional) Temperature Sensors.
4. A SG200 Battery Monitor for State of Charge (SoC), State of Health (SoH) and usage monitoring.
5. A 48V battery bank, sized appropriately for the loads. LiFePO₄ is ideal for this application.
6. A 48V Inverter/Charger.
7. A DC-DC converter to charge a 12-24V house bank, if present. This does not need to be sized for peak power, but only enough to keep up with the demands over time.