

6-Series Alternators

Designed for Recreational Applications

- Balmar's Top Selling Alternator Line
- 70A, 100A, 120A and 150A Versions
- Patented Smart Ready® Internal Regulator Technology
- Dual Fan Cooling
- High Airflow Frame
- Maximum RPM: 12,000
- USCG Title 33, ISO, SAE and CE Compliant
- Ideal for Modest Charging Upgrades



Smart Ready® 6-Series

Balmar **6-Series Alternators** deliver high-output performance in a compact, small-case package and are available in all four common mounting configurations (see page 6).

While all Balmar's high-output alternators are designed and recommended for use with our multi-stage voltage regulators, the **6-Series Alternator** utilizes Balmar's **Smart Ready® Technology**. If battery loads are relatively small and your engine is running frequently, the alternator's internal regulator may be sufficient to support your electrical needs without external regulation. If your vessel utilizes larger deep-cycle battery banks or the engine's duty cycle is less frequent (as is the case in most sailing applications), the **6-Series Alternator** combines and works seamlessly with Balmar's **ARS-5 Voltage Regulator** or **Max Charge Voltage Regulator**.

Purchased either individually or as a charging kit, **6-Series Alternators** can solve a multitude of charging problems at a reasonable price. All kits come with alternator, regulator and two temperature sensors.



Charging Kit

6-Series Output	Power Take Off	Mounting	Individual Alternator Part Number ⁽¹⁾	Alternator Kit with ARS-5 Regulator ⁽¹⁾	Alternator Kit with Max Charge Regulator ⁽¹⁾⁽²⁾	Altmount® Pulley Kit Required?
70 A	2.8 HP	1-2" Spindle	621-70-XX	621-VUP-70-XX	621-VUP-MC-70-XX	No
		3.15" Saddle	60-70-XX	60-YP-70-XX	60-YP-MC-70-XX	
100 A	4.0 HP	1-2" Spindle	621-100-XX	621-VUP-100-XX	621-VUP-MC-100-XX	
		3.15" Saddle	60-100-XX	60-YP-100-XX	60-YP-MC-100-XX	
120 A	4.8 HP	1-2" Spindle	621-120-XX	621-VUP-120-XX	621-VUP-MC-120-XX	Yes, If Dual Vee or Serp is Not Present
		3.15" Saddle	60-120-XX	60-YP-120-XX	60-YP-MC-120-XX	
		4.0" Dual Foot	604-120-XX	See Footnote 3		
150 A	5.2 HP	1-2" Spindle	621-150-XX	621-VUP-150-XX	621-VUP-MC-150-XX	
		3.15" Saddle	60-150-XX	60-YP-150-XX	60-YP-MC-150-XX	
		4.0" Dual Foot	604-150-XX	See Footnote 3		
70 A, 24V	5.6 HP	1-2" Spindle	621-24-70-XX	-	621-VUP-24-70-XX	
		3.15" Saddle	60-24-70-XX		60-YP-24-70-XX	
		4.0" Dual Foot	604-24-70-XX		See Footnote 3	

(1) "XX" Pulley Designations: "SV" = 1/2" Single Vee, "DV" = 1/2" Dual Vee, "K6" = K6 Serpentine, "J10" = J10 Serpentine.

(2) A Max Charge Regulator Kit is required for 24 volt, Dual-Alternator or Twin Engine Applications.

(3) A Charging Kit is Not Available, However the Components may be Purchased Separately.

How to Select the Correct Balmar Charging System for Your Vessel

Step 1: Determine your Electrical Load

All your device loads and expected duty cycles will clarify your expected daily battery discharge requirements. Add a safety factor.

Step 2: Identify your Battery Bank Technology and Capacity

How many batteries are in your bank and what is the total storage capacity?
 What type of batteries are employed? (Different technologies require different charging programs)

Step 3: Select your Alternator Output

The correct charging load depends on the battery technology and capacity.
 For example, an AGM battery can accept a 40% charge load, so a 300Ah bank of AGMs can accept 120A of charging from the alternator. Therefore you could utilize a 120A alternator to charge your bank as quickly as possible.

Step 4: Identify the Alternator Mounting Style Present on your Engine

The most common mounting styles are shown to the right:		
(A) 1" Single Foot (Spindle Mount)	"Motorola Style"	Balmar 621 Series
(B) 2" Single Foot (Spindle Mount)	"Delco Style"	Balmar 621 Series
(C) 3.15" Dual Foot (Saddle Mount)	"Hitachi Style"	Balmar 60 Series
(D) 4" Dual Foot (Saddle Mount)	"J-180 Style"	Balmar 604 Series

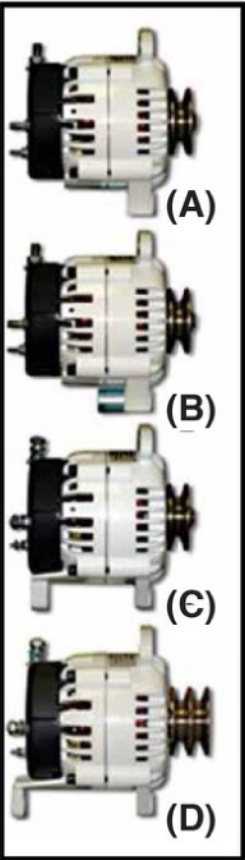

Step 5: Determine your Belt and Pulley Requirements

An AltMount® belt/pulley conversion kit may be required to handle your alternator Power Take-Off ("PTO") load.

Detailed toolsets for calculating loads and selecting the appropriate charging system for your vessel are available in the Balmar Catalog or at www.balmar.net

6-Series Alternator Specifications

Alternator Style: Small Case, Positive Field Excitation (P-Type)	Positive Output: Threaded Stud Stud Dimensions: M8 x 1.25"
Regulation: External P-Type (ARS-5 or MC-614), or Internal Smart Ready® Fixed Voltage Regulator	Lamp Output: D+ (low voltage / low current) Stud Dimensions: 10 x 24
Cooling: Dual Internal Fans	Grounding: Dedicated Terminal (Case Isolated) Stud Dimensions: M8 x 1.25"
Bearings: Sealed Bearings, Heavy Duty Radial (front & rear)	AC/Stator Output: 12 Pulse. Stator Output Wire included in Pigtail Plug.
Case Construction: Ventilated Cast Aluminum High Impact Plastic Rear Cover	Internal Voltage Regulation: 14.1 Volts (12V systems) 28.2 Volts (24V Systems)
Finish: White Power Coat	Diodes +/-: 3 Positive, 3 Negative; 50A Rated
Tensioning Arm Mount: Five Position Crown (M8 x 1.25")	Low RPM Cut-In: 1,320 rpm Max Alternator RPM: 15,000 rpm
Mounting Foot Bore: 60 & 604-Series: 8mm or 10mm 621-Series 1 inch: 1/2", 621-Series 2 inch: 3/8"	Normal Operating Temperature: 180 °F / 82° C Max Operating Temperature: 225° F / 108° C
Mounting Styles: 621 Series: 1" or 2" Single Foot (Spindle) 60 Series: 3.15" Dual Foot (Saddle) 604 Series: 4" Dual Foot (Saddle)	Ignition Protection Ratings: USCG Title 33, ISO J1187, CE, SAE 8846

6-Series Output Curves

Alternator output is dependent on a number of factors: battery condition and capacity, wire size, engine horsepower and engine RPM, battery temperature and alternator temperature. Of these factors, alternator speed and temperatures are the most important. The following graph describes alternator output based on two temperature levels (ambient (26° C) and hot (90° C)). Test voltages are set at 13.5V (for 12V units) and 27.0V (for 24V units).

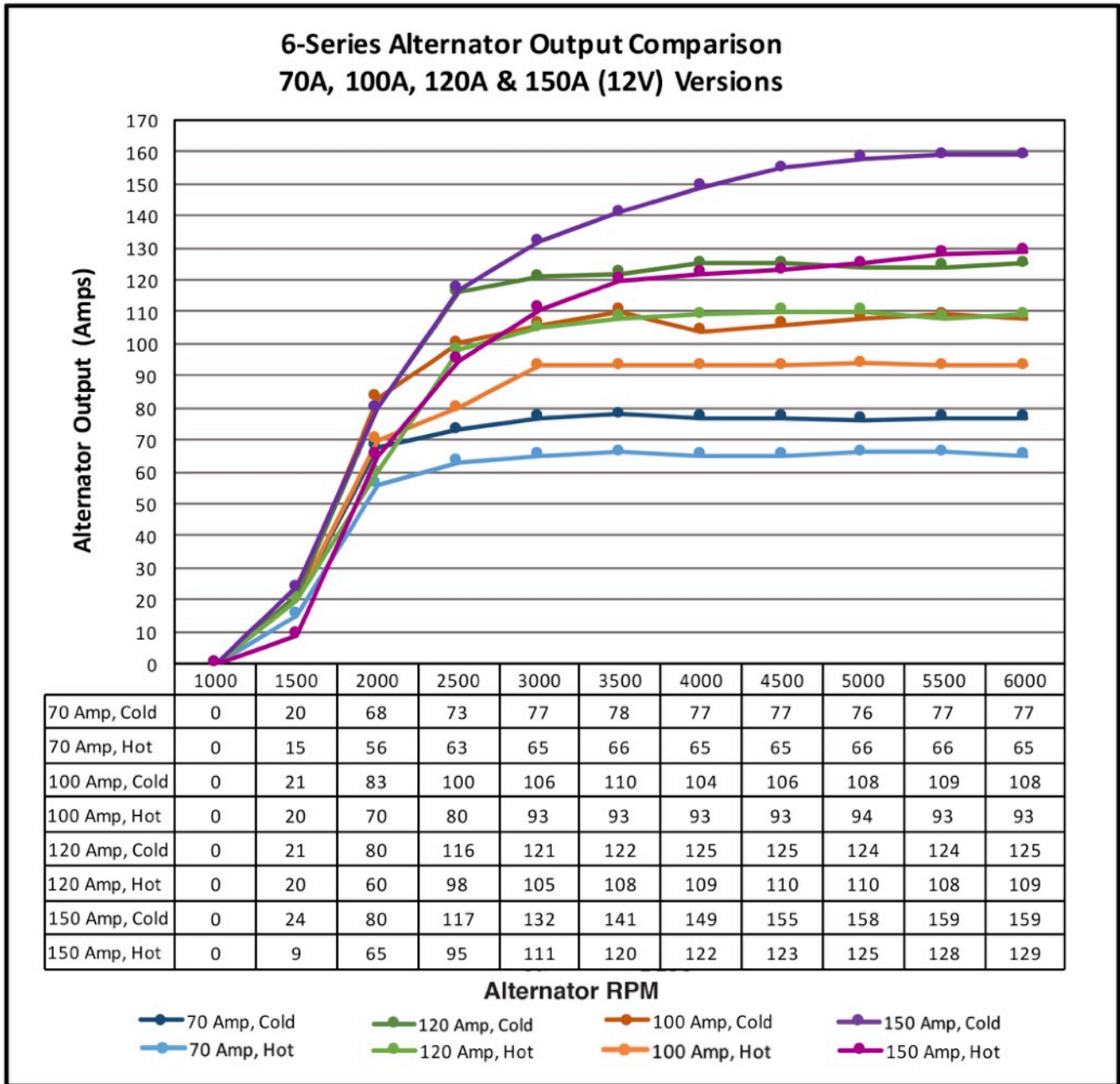

70A, 24V Alternator Outputs:

Engine RPM	500	750	1000	1250	1500	1750	2000	2250	2500	2750	3000
Typical Drive Ratio	2	2	2	2	2	2	2	2	2	2	2
Alternator RPM	1000	1500	2000	2500	3000	3500	4000	4500	5000	5500	6000
Cold	0	6	36	55	68	71	73	76	76	75	76
Hot	0	3	25	40	50	53	53	56	54	56	55

6-Series Dimensions

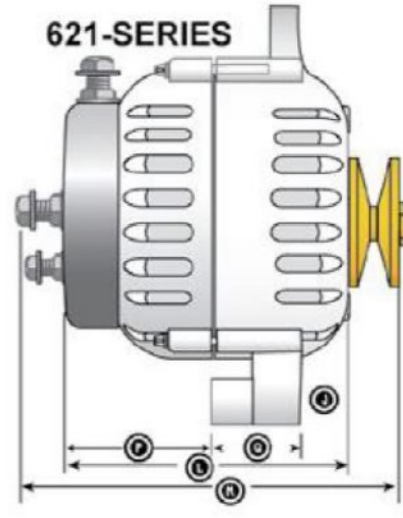
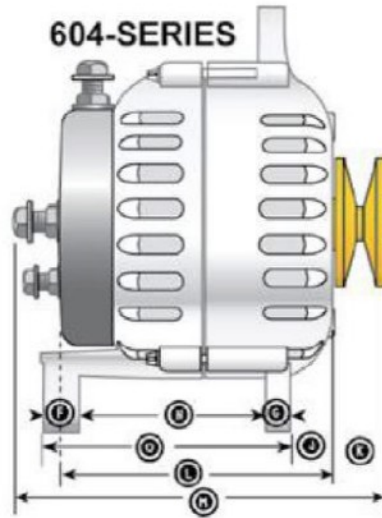
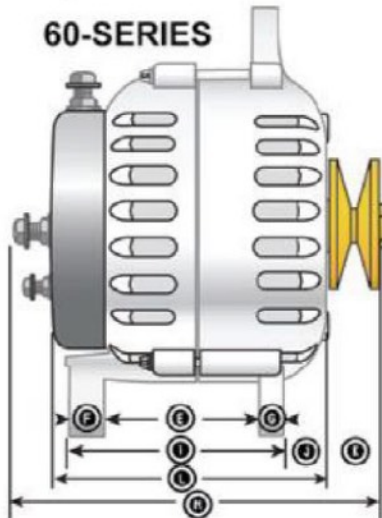
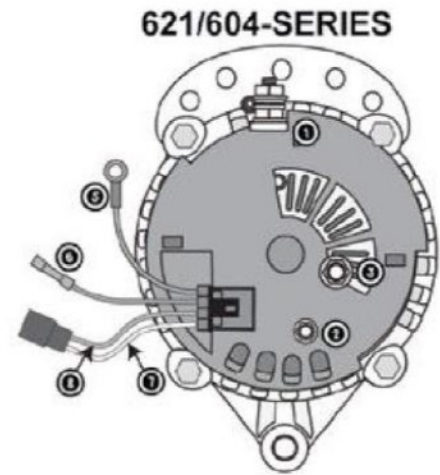
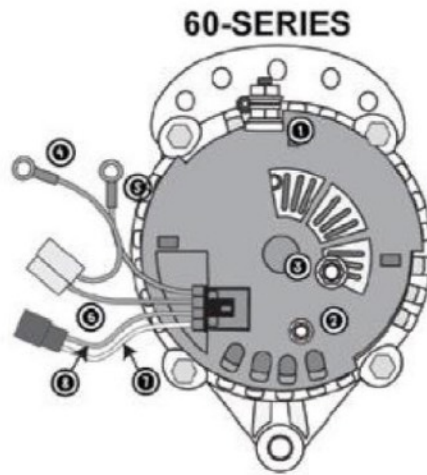
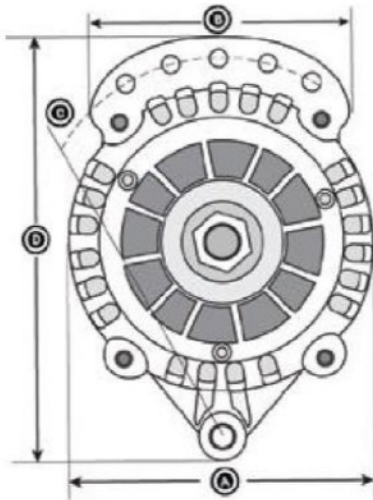

ITEM	DESCRIPTION	IN	MM
A	Case Diameter	5.35	136
B	Crown Width	4.02	102
C	Bolt-to-Bolt Center	6.60	167
D	Overall Height	7.50	190
E	60-Series Saddle Width (ID)	3.28	83
F	Rear Foot Width (incl. Bushing)	0.94	24
G	Front Foot Width	0.61	16
I	60-Series Mounting Saddle Overall	4.50	114
J	Front Foot to Case Front	0.50	13
K ₍₁₎	Single Vee (SV) Pulley Width	0.72	19
K ₍₂₎	Dual Vee (DV) Pulley Width	1.41	36
K ₍₃₎	K6 (Serpentine) Pulley Width	1.20	30
K ₍₄₎	J10 (Serpentine) Pulley Width		
L	Case Length Front-to-Back	5.08	129
M ₍₁₎	Overall Length (w/SV Pulley)	6.63	168
M ₍₂₎	Overall Length (w/DV Pulley)	7.28	185
M ₍₃₎	Overall Length (w/K6 Serp. Pulley)	6.90	175

ITEM	DESCRIPTION	IN	MM
M ₍₄₎	Overall Length (w/J10 Serp. Pulley)	7.13	181
N	604-Series Saddle With (ID)	4.15	105
O	604-Series Mounting Saddle Overall	5.18	131
P ₍₁₎	Case Rear to Foot (2" Foot)	2.50	65
P ₍₂₎	Case Rear to Foot (1" Foot)	3.50	94
Q ₍₁₎	Foot Width (2" Foot w/Spacer)	2.00	51
Q ₍₂₎	Foot Width (1" Foot no Spacer)	1.00	25

TERMINAL CONNECTION LOCATIONS	
1	Isolated Ground Terminal
2	Lamp (D+) Terminal
3	Positive Output Terminal
4	Lamp Wire (60-Series Only – Not Used) (BLUE)
5	Internal Regulator Sense Wires (RED)
6	Internal Regulator Ignition Wire (BROWN)
7	Stator/Tach Output Wire (WHITE)
8	External Regulator Field Input (BLUE)

Dimensions are provided for illustrative purposes. Contact Balmar Technical Support if detailed drawings are required.